

12" Drop Visor & Monster Drop Bow-Tie Visor for Kenworth Flat Windshield, 1999-2005

*Replaces factory stainless steel visor only, not compatible with fiberglass visor.
Part numbers 45030, 45031*

Before beginning the installation of your new RoadWorks® visor verify using the box label that you have the correct visor for your windshield type and model year. If you do not have the correct visor for your truck, call RoadWorks® Manufacturing, Inc. at 1-800-448-8741.

PLEASE READ THE DIRECTIONS COMPLETELY BEFORE BEGINNING.

Once you have determined that you have the proper replacement visor for your truck proceed with the removal of your old visor and the adjustable portion of the outer brackets, do not remove the cab mounted factory brackets from your truck. Set the hardware from the factory visor aside, it will be used in the installation of your new visor.

Installation

1. Arrange the brackets on a flat surface: the -12 goes on the outer driver's side, the -11 on the inner driver's side, the -14 in the center, the -16 on the inner passenger's side, and the -17 on the outer passenger's side (see Diagram #4 on reverse side).
2. Peel the PVC film from all of the brackets.
3. Install the -14 center bracket over the existing factory center bracket using the original hardware, do not fully tighten these bolts (see Diagram #4 on reverse side). Mark the top of the cab through the well nut holes on the bracket, then remove the bracket. Carefully drill ½" holes in the top of the cab, being careful not to damage the interior of the cab.
4. Reinstall the -14 center bracket using the original hardware and two ¾" hex bolts, lock washers, flat washers, and neoprene well nuts (see Diagram #5 on reverse side). Fully tighten these bolts.
5. Install the -11 and -16 inner brackets on the -14 center bracket using ¾" carriage bolts, flat washers, lock washers, and hex nuts (see Diagram #4 on reverse side). Do not fully tighten these bolts.
6. Install the -12 and -17 outer brackets on the outer factory brackets using ¾" carriage bolts, flat washers, lock washers, and hex nuts (see Diagram #4 on reverse side). Do not fully tighten these bolts.
7. Install the first visor skin using six ¾" carriage bolts, flat washers, lock washers, and hex nuts. Do not fully tighten these bolts. Repeat for the other skin. For convenience, peel the PVC away from the center joint only.
8. With both skins in place join them together at the center using three ¾" hex bolts, flat washers, lock washers, and hex nuts. Fully tighten the center bolts only.
9. Bolt the sides of the visor to the cab using the existing factory hardware. Do not fully tighten these bolts.
10. Install the -11/45050-26, -16/45050-24 outer most brackets to the visor skins using ¾" carriage bolts, flat washers, lock washers, and hex nuts (see Diagram #4 on reverse side). Do not fully tighten these bolts.
11. Mark the cab through the well nut hole on both outer brackets.
12. Remove the visor skins and drill ½" holes for the outer brackets in the position marked in step #10. Install the -11/45050-26 and -16/45050-24 brackets on cab using 1¼" hex bolts, flat washers, lock washers, and 1" neoprene well nuts. Do not fully tighten these bolts.
13. Reinstall the visor skins as described in step #7. Fully tighten all the bolts.
14. Peel the PVC film from the visor skins. This completes the installation.

12" Drop Visor & Monster Drop Bow-Tie Visor for Kenworth Flat Windshield, 1999-2005

DIAGRAM #1

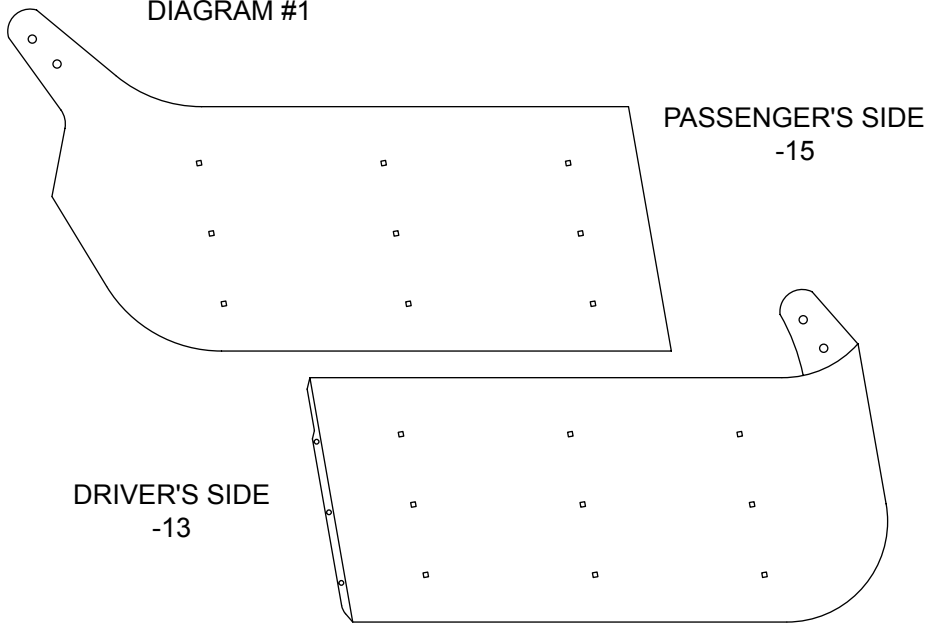

DIAGRAM #2

HARDWARE

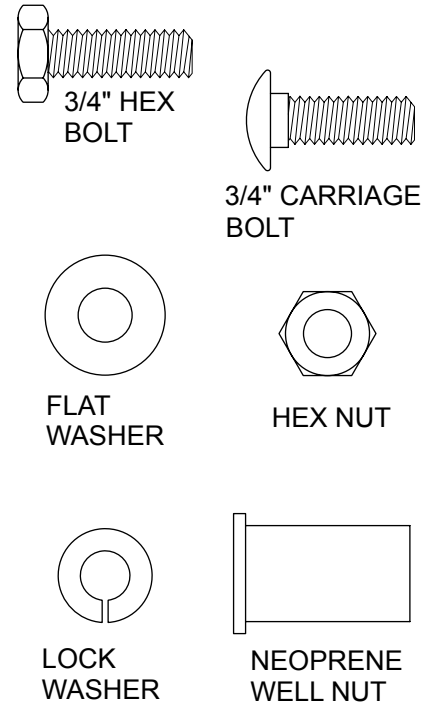

DIAGRAM #3

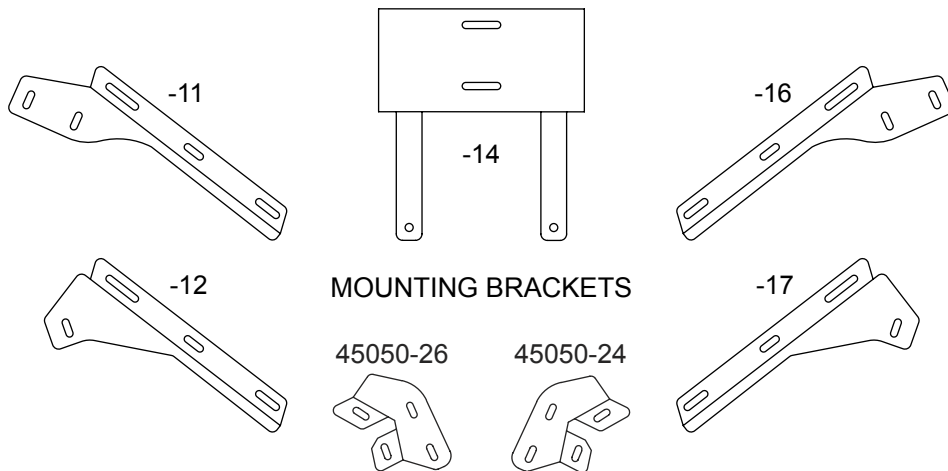

DIAGRAM #5

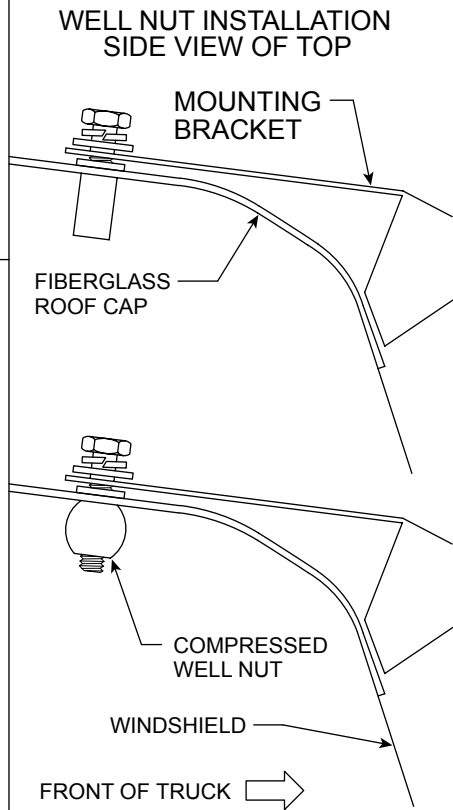

DIAGRAM #4

