

International 13.8" Drop Visor for i-Model Cabs with Lo-Roof Pro Sleepers

Do not install on Day Cabs

Part numbers 55100-55110

Before beginning the installation of your new RoadWorks® visor please verify that the visor you have purchased is for your cab and sleeper type. If you do not have the correct visor for your truck, call RoadWorks® Manufacturing, Inc. at 1-800-448-8741.

PLEASE READ THE DIRECTIONS COMPLETELY BEFORE BEGINNING.

Once you have determined that you have the proper replacement visor for your truck, proceed with the removal of your old visor. Set the hardware from the factory visor aside, it will be used in the installation of your new visor.

Installation

1. Arrange the brackets on a flat surface, the -14 goes on the outer driver's side, the -17 on the inner driver's side, the -02 in the center, the -18 on the inner passenger's side, and the -16 on the outer passenger's side (see Diagram #4 on the reverse side).
2. Peel the PVC film from all of the brackets.
3. Install the -02 center bracket in the factory center bracket location using the factory hardware, do not fully tighten this bolt (see Diagram #3 & #4 on reverse side). Attach the -17 & -18 brackets to the installed -02 bracket using $\frac{3}{4}$ " carriage bolts, flat washer, lock washer, and hex nuts. Do not fully tighten these bolts. See Diagram #4 on reverse side.
4. Install the -14 & -16 outer brackets using the factory hardware (see Diagram #3 & #4 on reverse side). Do not fully tighten these bolts.
5. Attach the two -01 backing plates together using $\frac{3}{4}$ " carriage bolts, flat washer, lock washers, and hex nuts. Rest the assembled backing plates in the cutouts of the visor brackets. Install the protective wire grommet in the center overlapping holes.
6. Fasten the -13 & -15 visor skins together using $\frac{3}{4}$ " hex bolts, flat washer, lock washers, and hex nuts. Fully tighten these bolts. For your convenience, peel the PVC away from the center joint only.
7. Place the assembled visor skins over the brackets and temporarily attach using $\frac{3}{4}$ " carriage bolts, flat washer, lock washers, and hex nuts. Do not fully tighten these bolts.
8. With the visor in place, mark the cab through the side holes in the visor skins. Remove the visor and drill the marked locations to $\frac{1}{2}$ " diameter, being careful not to damage the cab or its interior. Insert the well nuts into the side holes of the cab.
9. If the visor you are installing has lights, install them now using the provided hardware or grommets and harnesses.
10. Reinstall the visor skins using $\frac{3}{4}$ " carriage bolts, flat washer, lock washers, and hex nuts. Bolt the sides of the visor to the cab using $1\frac{1}{4}$ " hex bolts, flat washers, and lock washers. Fully tighten these bolts. If your visor has lights, feed the wiring through the previously installed protective wire grommet.
11. Fully tighten all of the remaining bolts including the bracket bolts from step #3 & #4.
12. Peel the PVC film from the visor skins. This completes the installation of your new RoadWorks® visor.

International 13.8" Drop Visor for i-Model Cabs with Lo-Roof Pro Sleepers

Diagram #1

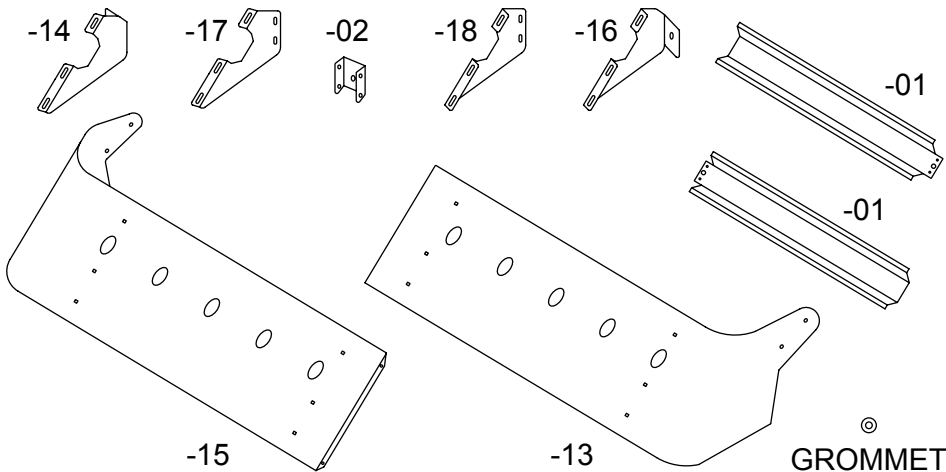

Diagram #2

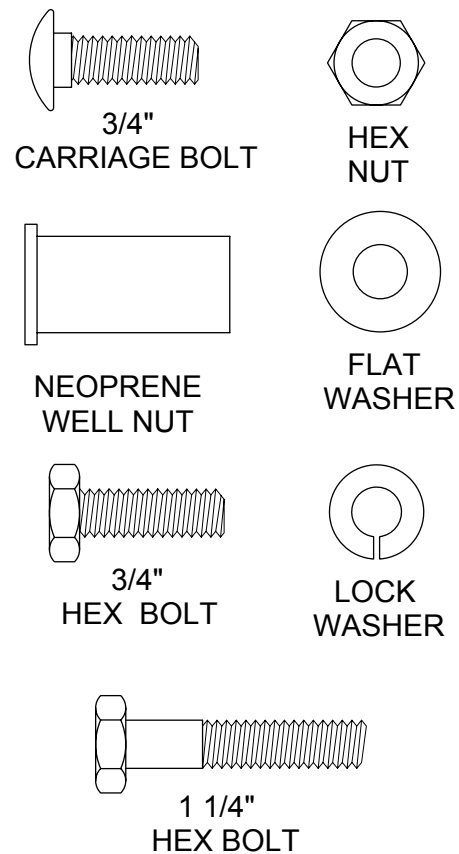

Diagram #3

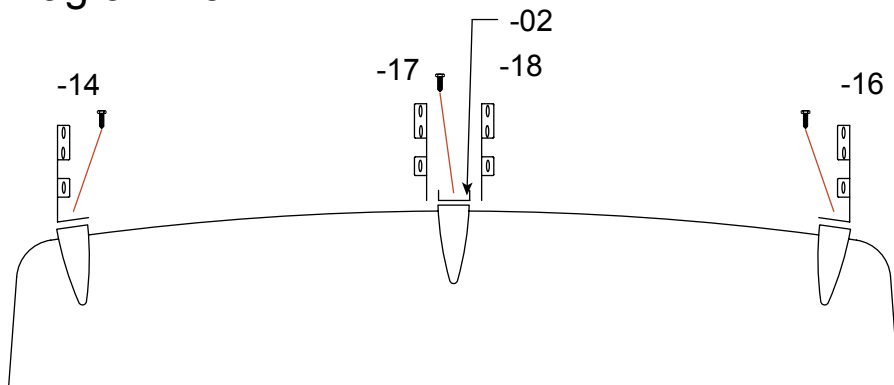

Diagram #4

